



Paw Prints

AUGUST 1, 1985

CLUB ACTIVITIES

- Aug 10 Club picnic, 3:00 p.m., Rob Wilson's
4630 Waterloo Road Canal Winchester
- Aug 28 Tech Session "How To Buy a GTO" 7:00 p.m.
Andy Syrkin's home, 9130 Muirkirk, Col.
- Sep 11. Club meeting at Plank's in German Village
888 South High Street, Columbus 6:30 p.m.
- Sep 14 25th anniversary cruize at Jerry's Drive
Inn, 4910 North High Street, Columbus

OTHER ACTIVITIES

- Aug 4 Antique/Classic Car Show, Hocking County
Fairgrounds, Logan. Auto parts, flea
market INFO (614) 385-6836
- Aug 24 Piqua Antique Car Club Show 8-5, Miami
25 County Fairgrounds, Troy INFO (513)
773-0241
- Aug 10 Crawford Car Meet, Hale Farm Village
11 Oak Hill Road, Bath. Saturday 10-5
Sunday 12-5 A\$3.50; C/CS \$2.50 INFO
(216) 721-5722

1100-0011

SECRETARY NOTES

A club meeting was held on July 17 at Jerry's Drive Inn. Rob Wilson read the treasurer's report stating a balance of \$473.25. Much appreciation was given to Jeff Inskip and Karen and Rob Wilson for their efforts on our new newsletter, PAW PRINTS. Two guests that became members were Kerry Parker, and Bob Shaull. Hopefully by picnic time an updated roster will be available for all members.

Nine club members and their families attended the GTO Nationals in Bloomfield Hills. Committee reports were updated, and talk about a Drag Day continued. Tentatively this is set for September 22 at National Trail Raceway. There will be a \$5.00 admission fee.

Our August picnic will double as our monthly meeting, also Nick Anspach will be in charge of our picture roster at the picnic so please drive your GTO's. In September we will be holding our monthly meeting at Planks in German Village on September 11th. Finally, duties of future officers were discussed. The meeting adjourned at 8:15 p.m..

GTO Association of Central Ohio

Officers

President Bill Barton
3062 Scioto Trace
Columbus, Ohio 43220
876-8151

Vice Presidents Nick Anspach
Box 265
Jacksontown, Ohio 43030
246-5145

Jeff Inskip
3193 Dublin-Granville Road
Columbus, Ohio 43229
891-7821

Treasurer Rob Wilson
4630 Waterloo N. W.
Canal Winchester, Ohio 43110
837-5859

Secretary Karen Wilson

TREASURER'S REPORT

Balance from July	\$461.25
Tee Shirt Sale	9.00+
Renewal	15.00+
New membership	10.00+
	<u>\$495.25</u>
<u>Expenses:</u>	
Stamps	22.00-
<u>Ending Balance:</u>	\$473.25

- 1 - COVER & FILTER ASSY.
- 2 - SHROUD & SEAL ASSY.
- 3 - STUD
- 4 - ORNAMENT
- 5 - PIPE

- 1 10-20 LB. IN.
- 2 15-20 LB. IN.

TORQUE SYMBOL IS ADJACENT TO CALLOUT FOR MEMBER TO BE TORQUED.

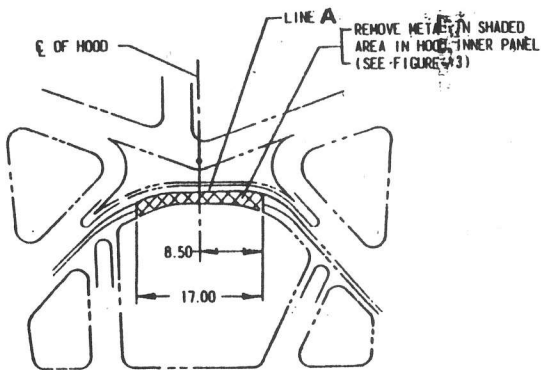

1965 thru 1967 GTO HOOD RAM AIR BOX INSTALLATION PROCEDURE FOR BOTH PART NUMBERS 530 and 540.

FIGURE #1 PROCEDURE FOR INSTALLING PACKAGE

- STEP #1 REMOVE EXISTING UNDERHOOD PAD (IF SO EQUIPPED), HOOD ORNAMENT, AIR CLEANER AND AIR CLEANER STUD. RETAIN HOOD ORNAMENT NUTS AND AIR CLEANER NUT. SEE FIGURES #2 & #6 AND SEE CAUTION NOTE BELOW.
- STEP #2 MODIFY HOOD ORNAMENT BY REMOVING METAL AND RIBS AS SHOWN (SHADED AREA) IN FIGURES #3 & #4.
- STEP #3 CUT HOOD INNER PANEL ALONG LINE "A" (17 INCHES WIDE) AND REMOVE METAL (SHADED AREA) AS SHOWN IN FIGURES #1 & #3.
- STEP #4 CUT HOOD OPENING REINFORCEMENT ALONG LINES B AND C. SEE FIGURES #2 & #4 FOR AREA TO BE CUT (SHADED AREA).
- STEP #5 AFTER MODIFYING HOOD INNER PANEL, HOOD OPENING REINFORCEMENT AND ORNAMENT INSTALL MODIFIED HOOD ORNAMENT USING EXISTING NUTS AS SHOWN IN FIGURE #2.
- STEP #6 INSTALL SHROUD & SEAL ASS'Y, STUD, AIR CLEANER ELEMENT AND COVER AND L EXISTING NUT AS SHOWN IN FIGURE #6.

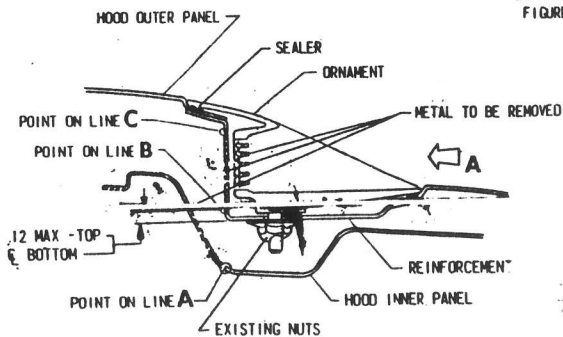

FIGURE #3

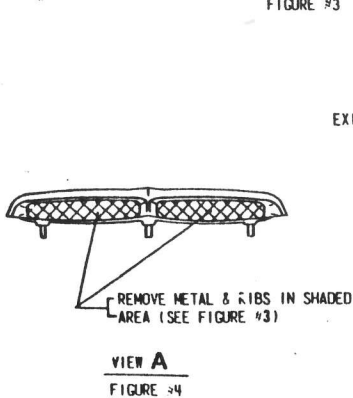

FIGURE #4

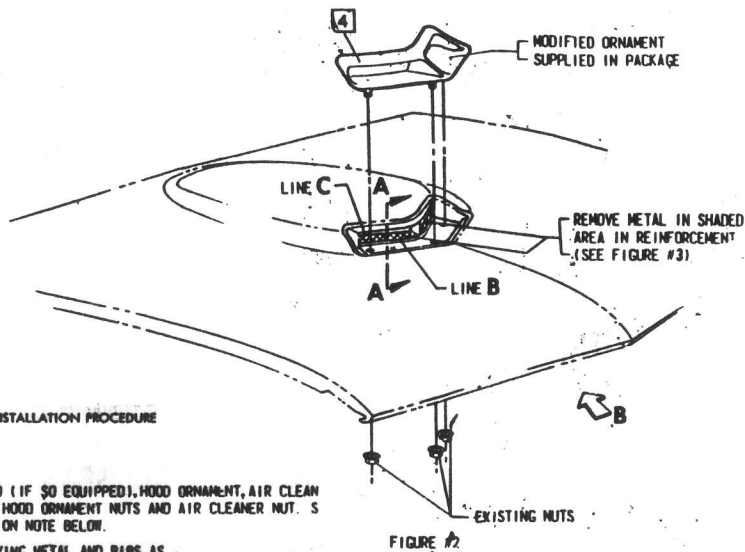
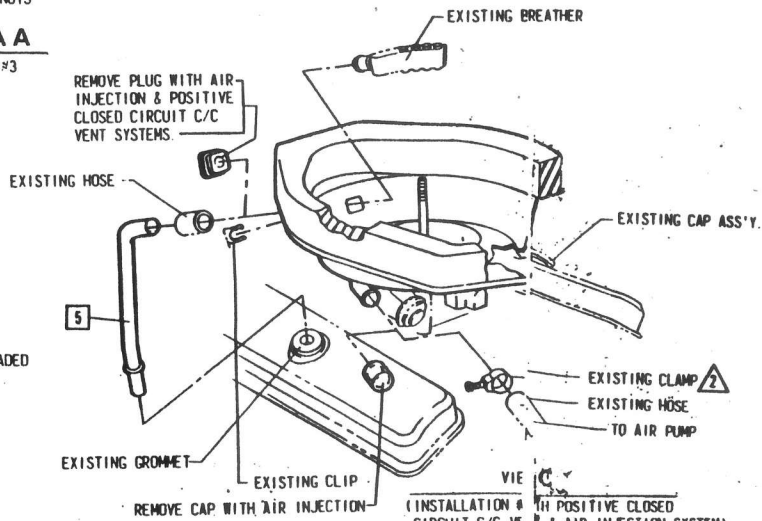

FIGURE #2

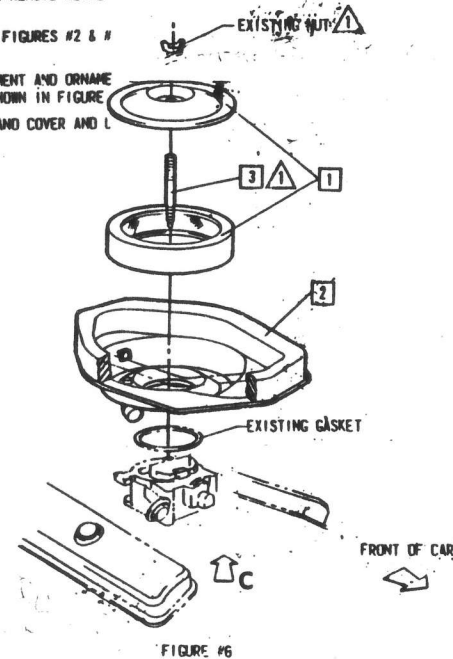
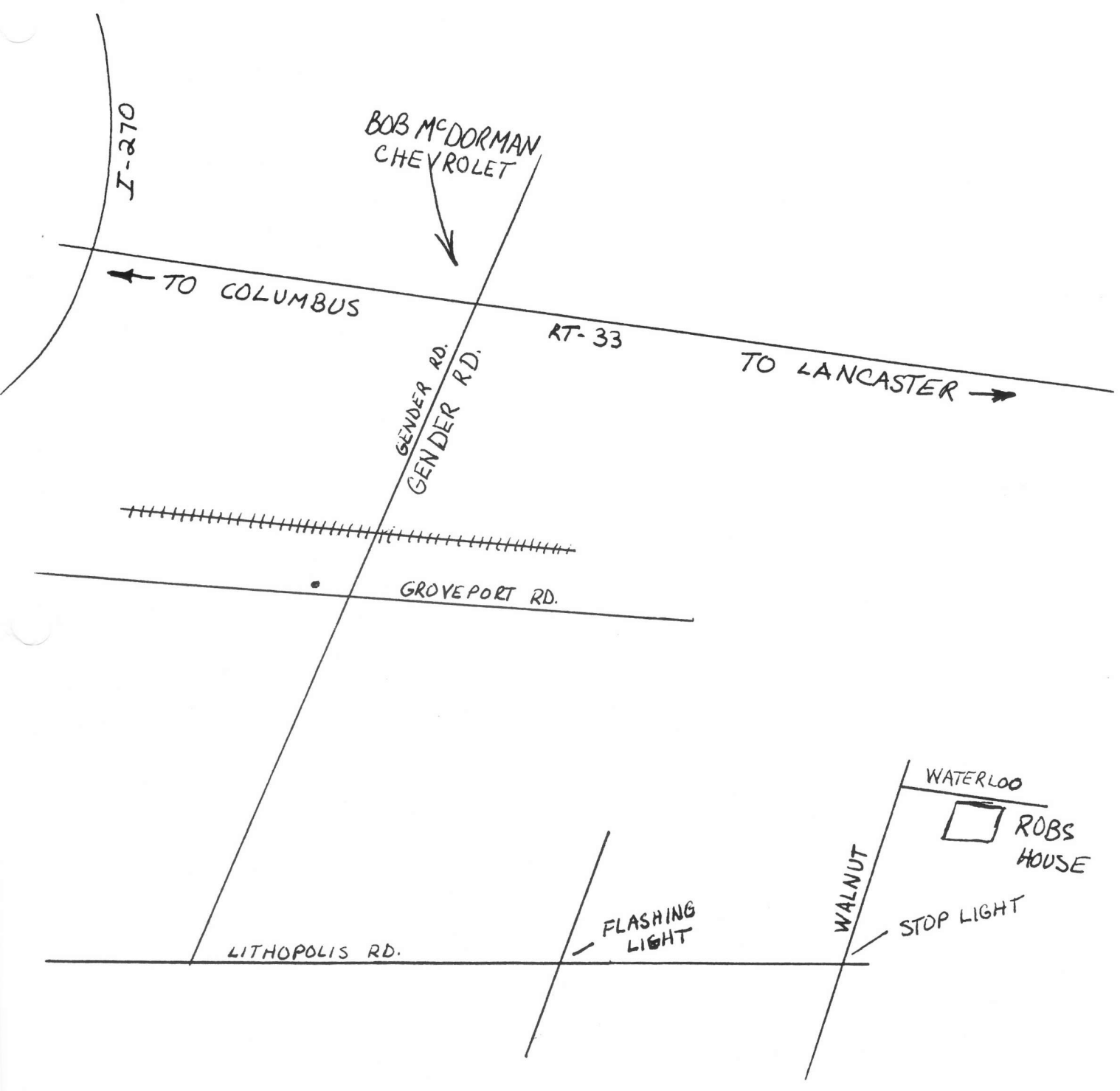

FIGURE #6



A club picnic will be held at Rob Wilson's home on Saturday August 10 at 10pm. We ask that you bring your own table settings, lawn chairs and either a dessert or covered dish. Bratwurst hot dogs and pop will be provided. Please drive your GTO's so as a picture roster may be compiled at a later date. Any further questions may be directed to Rob at 837-5859. (map enclosed)

Come, Join us
in our....

Return to the good times! '50s Style Saturday Nite Cruisin'



7:00pm
May thru October, '85

with the

Strokers

ROD'n'CUSTOM ASSN.
COLUMBUS, OHIO

at the...
Hunters Ridge
Shopping Mall



at the **Kmart**
The Saving Place™

in Gahanna, Ohio... Lot
HAMILTON ROAD & I-270

- MAY - 4th
 - JUNE - 1st
 - JULY - 6th
 - AUG. - 3rd
 - SEPT. - 7th
 - OCT. - 5th
- the First Saturday Nite of each month!

HOW TO GET HERE !!

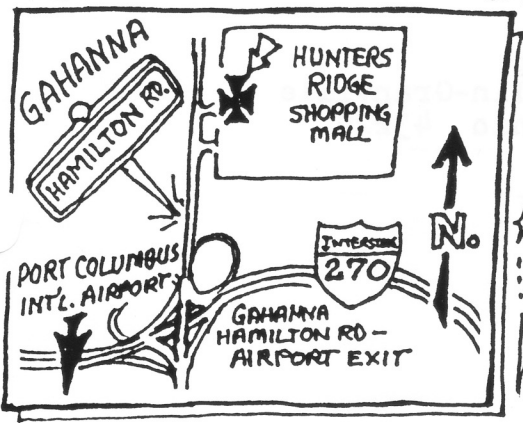

JW/85

WE NEED YOUR RESPONSES

Our club is dedicated to the correct restoration of the GTO. We would like to have some responses and/or elaborations to add to this statement about our club. We would like to know just what everyone wants and expects from this club.

SPONSORSHIP

Incoming persons wishing to join The GTO Association of Central Ohio will be required to have a sponsor from the existing membership.



Paw Prints

4630 Waterloo N. W.
Canal Winchester, Ohio 43110



Jeff Inskeep
3193 E. Dublin-Granville
Columbus, Ohio 43229



A club meeting was held Wednesday evening at Plank's Cafe'. Eleven members were in attendance. The treasurer's report stated a balance of \$413.62.

Old business conducted included a review of duties of the officers, additions and changes were made. Enclosed is a brief outline concerning these duties. A motion was passed that officers would be brought to office by yearly ballot vote.

Jeff Inskeep has volunteered to be newsletter editor for the remainder of the year and also 1986.

It was decided that officers will not be included in the 1986 free memberships that will be awarded for high points.

Randy Motter reported on the Drag Day. Sundays will be considerably cheaper than Saturdays. Tentative date will now be October 12. RSVP Randy Motter

New business conducted, we have decided against a Halloween party, and should concentrate on plans for a Christmas party.

The meeting adjourned at 8:20 pm. Our next meeting will be held Wednesday, October 9th at 7:00 pm. Jimmy Dean Restaurant, 5730 Cleveland Ave., 882-3254. Nominations for officers will be taken at this meeting.

TREASURER'S REPORT

Ending Balance	473.25
Picnic supplies	12.57
Beef	23.56
Stamps	22.00
	<u>415.12</u>

Anyone wishing to help at the Columbus 500, please contact Bill Barton for details. 876-8151